

Trailer towing

Driving with a trailer

General information

Your vehicle is primarily intended for transporting people and luggage. However, if you drive with a trailer, follow the technical requirements, the operation and driving tips, and the legal regulations.

Driving with a trailer affects the vehicle's energy usage, performance, and wear. It also requires greater concentration from the driver.

A retrofitted trailer hitch must be installed according to the instructions provided by the manufacturer ⇒ *page 134*.



WARNING

Do not transport any people in a trailer due to the risk of fatal injury.

Operating instructions

Towing capacity

The permitted towing capacity must not be exceeded under any circumstances ⇒ *page 299*.

You can drive up larger inclines if you are not using the maximum towing capacity.

Tongue weight

The maximum permitted tongue weight of the trailer drawbar on the trailer hitch ball head must not be exceeded.

For driving safety, Audi recommends always using the maximum permitted tongue weight, but do not exceed this weight. Having the tongue weight too low affects the handling of the vehicle and trailer.

You can determine the tongue weight using a tongue weight scale, a bathroom scale, or a public weigh station, for example. If the tongue weight differs, it can be adjusted by distributing the load in the trailer correctly. If the tongue weight meets the specifications, then the load in the trailer should not be changed.

Load distribution

Poor cargo load and distribution can negatively impact vehicle handling. Load the vehicle and trailer based on the following criteria as much as possible:

- Store objects in the vehicle luggage compartment, if possible. The vehicle should always carry the heaviest possible load and the trailer should have the lightest possible load.
- Distribute the load in the trailer so that the heavy objects are as close to the axle as possible.
- Secure objects so that they do not slide.
- Utilize the maximum permitted tongue weight if possible.

Speed

Adhere to the legal speed limits. Follow the legal regulations that are applicable in the country where you are operating the vehicle.

As the speed increases, the driving stability of the vehicle and trailer decreases. Therefore you should not exceed the maximum legal speed limit when there are unfavorable road, weather, and/or wind conditions. This especially applies when driving downhill.

Hill

When you start driving uphill or downhill, the vehicle and trailer may tilt or sway sooner than when driving on a level surface. If small swaying movements have already occurred, you can stabilize the trailer by firmly braking immediately. Never attempt to “straighten out” the vehicle and trailer by accelerating.

reduce the speed and use the recuperation braking effect ⇒ *page 98* to relieve the brakes ⇒ .

Exterior lighting

Follow the legal regulations for lighting on your trailer that are applicable in the country where you are operating the vehicle. If necessary, contact an authorized Audi dealer or authorized Audi Service Facility for more information. ►

Before you start driving, check all lighting equipment on the trailer while it is hitched to the vehicle.

The headlight range control automatically adjusts the light range of the headlights.

The turn signals are activated in trailer mode if the  indicator light blinks. If a turn signal on the trailer or on the vehicle fails while in trailer mode, the indicator light will **not** blink twice as fast to indicate this.

Outside mirrors

Make sure that you can also observe the traffic area behind the vehicle using the exterior mirrors, and use additional exterior mirrors if necessary. Adjust the additional exterior mirrors so that you have a sufficient visibility behind the vehicle. Follow the local legal regulations for installing additional exterior mirrors.

Tires

Set the tire pressure on your vehicle for a “full load”; see the tire pressure sticker ⇒ *page 257*. If necessary, also adjust the tire pressure on the trailer according to the manufacturer's specifications.

The trailer and the vehicle should be equipped with winter tires when driving in winter temperatures.

Driver assistance systems

Connecting or disconnecting a trailer/rear carrier system can change the alignment of the sensors/cameras.

To ensure the driver assistance systems can function correctly, switch the ignition off and then back on again each time an object is connected to the trailer hitch or disconnected from it.

Overrun brakes

If your trailer is equipped with an overrun brake, it must be correctly adjusted and function correctly. When using a trailer with overrun brakes, first brake gently then quickly. This reduces the risk of jerking while braking if the trailer wheels lock up.



WARNING

Constant braking causes the brakes to overheat and can substantially reduce braking performance, increase braking distance, or cause complete failure of the brake system.



Note

Attachments retrofitted on the vehicle may cause damage, especially on the trailer hitch ball head. In cases of damage, have the function checked by an authorized Audi dealer or authorized Audi Service Facility.



Tips

- Block the wheels with chocks when parking on inclines if the trailer is loaded.
- Audi recommends having the vehicle inspected between the inspection intervals if you tow a trailer frequently.

Air suspension

Applies to: vehicles with air suspension

Requirement: all vehicle doors must be closed. The Audi drive select **comfort** mode ⇒ *page 106* is selected before you connect the trailer ⇒ .

Setting trailer mode

- ▶ Applies to MMI: select on the home screen: **VEHICLE > Settings & Service > Air suspension: trailer**.
- ▶ Switch trailer mode off again when you are no longer towing a trailer.

For vehicles with a factory-installed trailer hitch, the air suspension trailer mode will automatically switch on if you connect the trailer connector to the socket.

When using rear carrier systems that are mounted directly on the trailer hitch ball head, you can also switch trailer mode off manually.

If you have to drive through difficult road conditions, you can raise the vehicle again after hitching the trailer or after ensuring the tongue weight is correct. To do this, select the Audi drive select **offroad** or **allroad** mode ⇒ *page 106*, or ▶

select **Raise** to create the maximum ground clearance ⇒ *page 107*.

! Note

- Never turn off trailer mode while driving when a trailer is hitched, because then the restrictions for controlling the vehicle level will be turned off.
- Driving with a trailer on unpaved roads when the vehicle is raised may change the vehicle handling. Adapt your speed.
- Note that the vehicle will lower automatically at certain speeds if you have lifted the vehicle manually.
- Be sure to adhere to the applicable tongue weight for your vehicle ⇒ *page 131*. Select the Audi drive select **comfort** mode before connecting the trailer. The tongue weight and vehicle height must be coordinated with one another.

i Tips

Even when lowering manually, the vehicle level will not lower more than the amount specified in the Audi drive select **comfort** mode.

Trailer hitch

Introduction

Only use a trailer hitch with a removable ball hitch mount and ball hitch. The trailer hitch must be permitted for the vehicle, the trailer and the permitted total weight of the trailer being pulled. Above all, it must be securely and safely attached to the vehicle trailer.

Never mount a trailer hitch on the bumper. The trailer hitch must be mounted in a way that does not impair the function of the bumper. Do not make any modifications to the brake system.

Check regularly if the trailer hitch is securely mounted. Always follow the instructions given by the trailer hitch manufacturer.

! WARNING

Never mount a "weight-distributing" or "load-balancing" trailer coupler as the trailer hitch. The vehicle was not designed for these types of trailer hitches. The trailer hitch can malfunction and the trailer can separate from the vehicle, which increases the risk of an accident.

Using the trailer hitch

Applies to: vehicles with trailer hitch

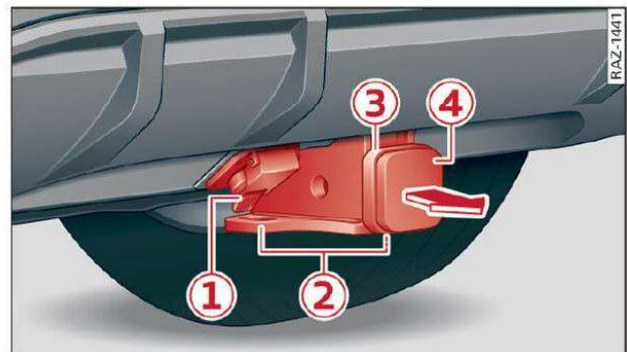

Fig. 92 Rear bumper: trailer hitch

The trailer hitch of your vehicle consists of the receiver (3), the connector¹⁾ (1) or connector retainer, two eyelets (2) for the safety chains, and the receiver cover (4).

The receiver (3) is suitable for securing a removable ball hitch mount with a ball head, for example when towing a trailer ⇒ .

- ▶ In order to use the trailer hitch, pull the cover (4) out of the receiver (3) in direction of the arrow.
- ▶ Check the receiver (3) for dirt and clean it if necessary.
- ▶ When towing a trailer, use the trailer connector¹⁾ (1) and secure the safety chains using the eyelets (2).
- ▶ To prevent dirt from entering the receiver (3), close it with the cover (4) after using it. ▶

¹⁾ In certain countries.

WARNING

- For your own safety, read the installation instructions provided by the ball hitch mount manufacturer.
- There is a risk of an accident if the ball hitch mount is installed incorrectly. The ball hitch mount must be secured in the receiver  correctly. The same applies to accessories that are secured in the receiver.
- Only use a ball hitch mount with ball head suitable for your vehicle and your trailer.
- To reduce the risk of injury, always remove the ball hitch mount if no trailer is mounted.
- To reduce the risk of an accident, contaminants on the trailer hitch must be removed because otherwise the ball hitch mount might not be secured correctly in the receiver.

Tips

- No ball hitch mount or ball head is provided with the trailer hitch. You can purchase these at specialty stores.
- The eyelets on the trailer hitch are only intended for securing the trailer safety chains.

Driving with a trailer

Trailer brakes

If the trailer has its own brake system, then follow the manufacturer specifications. However, the brake system on the trailer must never be connected to the vehicle brake system.

Safety chains

Make sure the safety chains are correctly applied when pulling a trailer. The chains should hang enough so that the trailer can drive around curves. However, they must not touch the ground.

WARNING

If the trailer is equipped with electronic brakes, these brakes cannot be activated by a factory-installed control system, which increases the risk of an accident.

Retrofit installation

You can find out if your vehicle is equipped with a retrofitted trailer hitch at an authorized Audi dealer or authorized Audi Service Facility.

An authorized Audi dealer or authorized Audi Service Facility knows the specifications for retrofitting a trailer hitch and any necessary technical requirements.

WARNING

- Only have the additional trailer hitch installed by an authorized Audi dealer or authorized Audi Service Facility.
- There is a risk of an accident if the trailer hitch is installed incorrectly.
- For your own safety, read the assembly instructions provided by the trailer hitch manufacturer.

Note

Connecting the socket incorrectly could cause damage to the vehicle electrical system.